



In-line duct fans

SILENTUB-100

SILENTUB-200



Transfer axial fan offering a very low noise level and specifically designed to work through a duct or to be flush mounted into the wall, ideal for ventilating small areas or to exchange heat between adjoining rooms. Fitted with single phase motors 230V-50Hz, IP44, Class II, with ball bearings for enhanced working life and assembled on silent-blocks.

+ Attributes



Back draft shutter
SILENTUB-100 is fitted with an automatic back draft shutter to prevent air entry and limit heat leakage when the extractor is not operating.



Silent-blocks
Motor mounted on silentelastastic block to absorb vibrations and reduce noise transmissions.

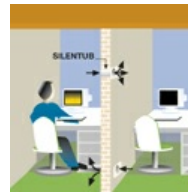

SILENTUB-100 can be flush mounted into the wall, ideal for ventilating small areas or to exchange heat between adjoining rooms.

+ Technical characteristics

Model	Speed (rpm)	Maximum absorbed power (W)	Ø duct (mm)	Air volume at free discharge (m ³ /h)	Sound pressure level* (dB(A))	Weight (kg)
SILENTUB-100	2450	12	100	100	37,5	0,5
SILENTUB-200	2350	16	120	190	42	0,7

* Sound pressure level measured at 1,5 m, at the fan inlet, in free field.

+ Dimensions

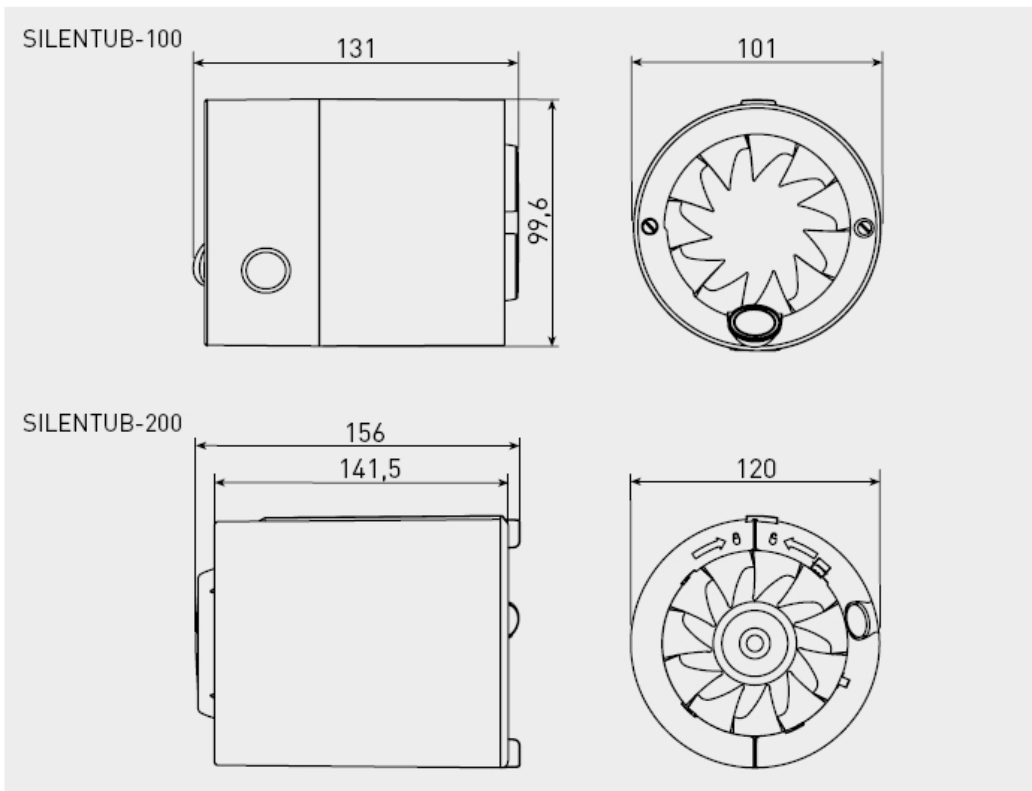

+ Curves

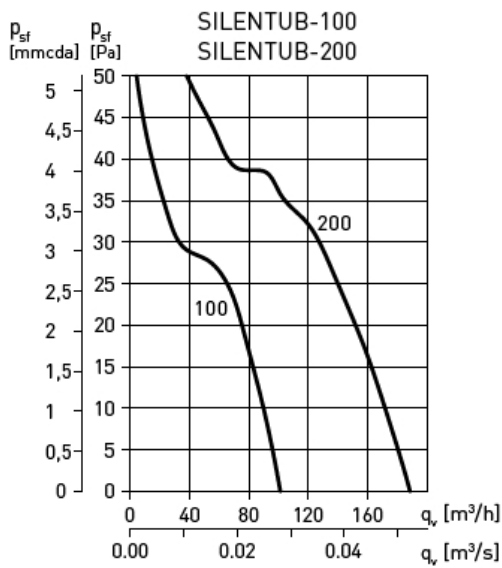

+ Mounting Accessories



Mounting foot
PIE-100/120
Support for wall fixing
(accessory)



GSA-100
Flexible aluminium
ducting.



GR-100
Plastic exterior
grille.



CX-80/125
Worm drive ducting
clip.



PER-100W
Exterior back
draft shutter.